

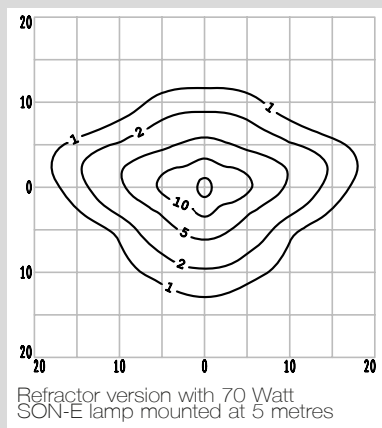

P514

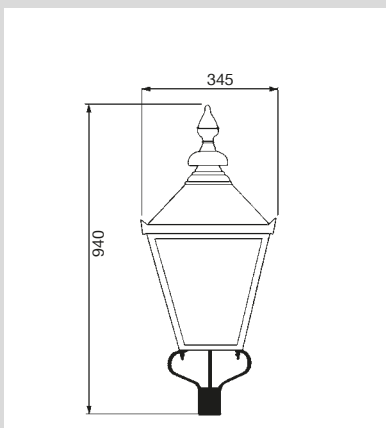

Recommended Applications:

Minor roads, residential areas, shopping areas, squares, parks, footpaths, rail, conservation areas.

Mounting Height:

4 - 6m for post-top or wall-bracket fixing.

Wind area:

0.24m²

Spigot:

76mm x 76mm

IP Rating:

IP65 Lamp compartment
IP54 Gear compartment

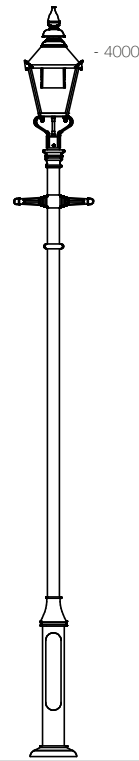
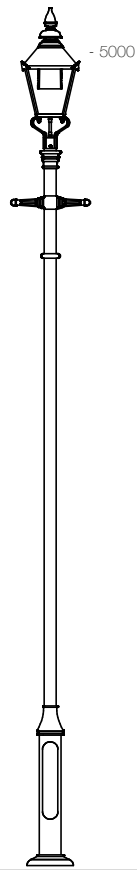
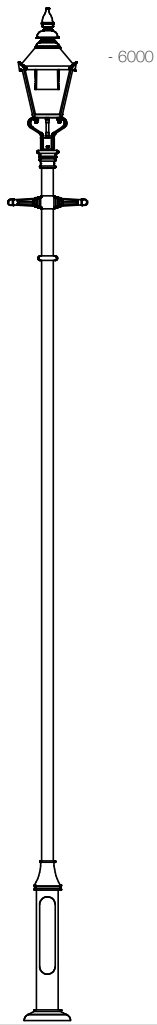

Mounted on CU Phosco Forest column fitted with Promenade conversion kit

P514

Square Victorian period lantern for situations needing a traditional lantern. Two modern optical system options give versatility of applications.

MATERIALS AND FINISHES

- Black vandal-resistant body
- Traditional steel powder coated post top mounting
- Clear vandal-resistant one-piece bowl.
- Integral control gear accessed through hinged canopy
- Sealed lamp compartment
- Asymmetrical light distribution refractor

OPTIONS AND EXTRAS

- Miniature photocell option
- Road lighting reflector system
- Wall bracket and corner wall brackets option
- Choice of RAL colours at extra cost
- Option of pre-wiring with suitable length of cable

Traditional Lighting

Traditional lighting covers those luminaires with a “heritage” style of design. The traditional luminaires made by CU Phosco Lighting are designed for road lighting and amenity lighting and are manufactured to the high specification expected in this market. All CU Phosco Lighting traditional luminaires have highly efficient photometric control either by multifaceted refractors for road and amenity lighting or with full cut-off reflectors where low visibility of the light source is critical.

New lamps are continually being developed and the CDO lamp is particularly suitable for traditional lighting as it gives a very white light up to 92 Lumens per Watt efficiency level. CU Phosco Lighting’s 70W CDO-TT reflector can be fitted to many of our traditional fittings.

P514 Lantern			Wind Area	0.20m ²	
Description	Product Number	Weight	Description	Product Number	Weight
Luminaire Reference	P514	8.6 kg			
50W SON control gear	50SON or SONT	1.6 kg	50W SON electronic control gear	50SONELE	0.5 kg
70W SON control gear	70SON or SONT	1.9 kg	70W SON electronic control gear	70SONELE	0.5 kg
100W SON control gear	100SON or SONT	2.1 kg	100W SON electronic control gear	100SONELE	0.5 kg
150W SON control gear	150SON or SONT	2.8 kg	150W SON electronic control gear	150SONELE	0.8 kg
35W CDM control gear	35CDMT	1.7 kg	35W CDM electronic control gear	35CDMELE	0.2 kg
70W CDO control gear	70CDOET or CDOTT	1.9 kg	70W CDM electronic control gear	70CDOELE	0.5 kg
100W CDO control gear	100CDOET or CDOTT	2.8 kg	100W CDM electronic control gear	100CDOELE	0.8 kg
150W CDO control gear	150CDOET or CDOTT	2.8 kg	150W CDM electronic control gear	150CDOELE	0.8 kg
42W PLT	42PL	0.2 kg	*45W Cosmopolis	45COSMO	0.8 kg
57W PLT	57PLT	0.2 kg	*60W Cosmopolis	60COSMO	0.8 kg
			*90W Cosmopolis	90COSMO	0.9 kg
			*140W Cosmopolis	140COSMO	0.9 kg
Options					
Reflector (SON-E)			RT		-
Reflector (SON-T)			RF		-
Miniature 1 part photocell				MINI	-
Special colour RAL number				RAL	-
Pre-wired with suitable length of cable				CBL	-

* Supplied as remote gear only