



P400/T400 SYSTEM



Recommended Applications:

Mounting Height:

Wind area:

Spigot:

IP Rating:

Motorways, major roads, railways, city centres, tunnels

Various

0.11m²

76mm x 76mm

IP65

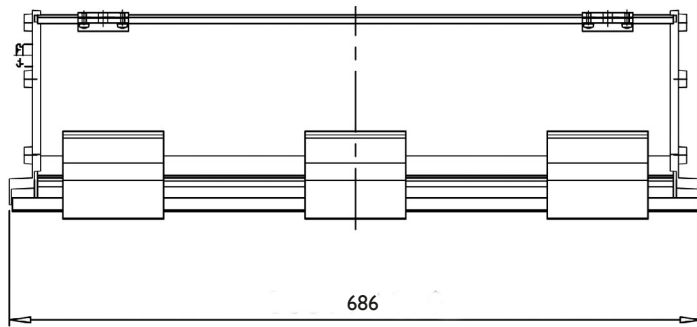

Single 600w SON-T Max

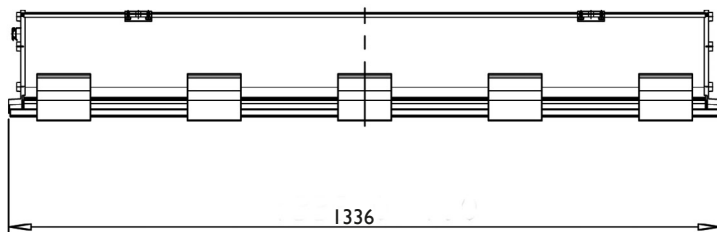
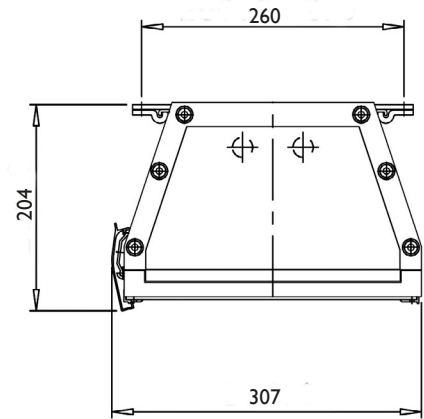

Twin 36w Master TL-D

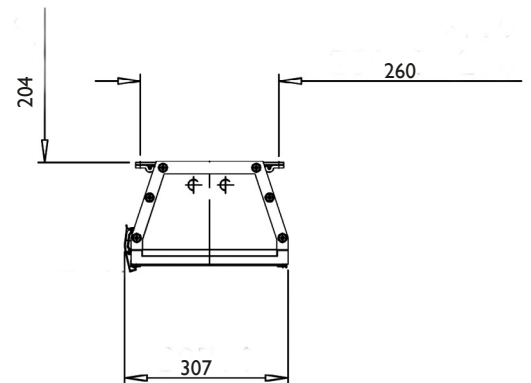

P400/T400 SYSTEM

The P400 system covers a wide range of catenary and tunnel luminaires. They are all dust tight and jet proof to IP65. The body is manufactured from aluminium which is first heavily anodised and then powder coated with a glass front. The P400 is a front opening luminaire with either full length hinges and clamps or individual hinges and clamps as specified. Two full length internal ducts are provided to facilitate through wiring. Cable entry is either through the sides or ends of the body as required.

The P400 has variable length and mounting arrangements and can be customised to suit the project requirements. It takes a range of reflectors with single or twin lamp capabilities and transverse or longitudinal distributions. It can also be adapted for tunnel lighting (T400) to suit the particular environmental requirements for low smoke 300 halogen materials.

An isolator can be fitted in each luminaire to cut power supply on the opening of the luminaire. The control gear is fitted to easily removable gear trays which may be provided with plug and socket connections. Dimming equipment can also be fitted within the body of the luminaire.

These luminaires are compatible with a wide range of remote or centrally managed control systems.

For more information on customising your P400/T400 system please contact our sales team.

OPTIONS AND EXTRAS

- Catenary or Tunnel Specification
- Miniature or NEMA socket/photocell options for P400
- Dimming
- Choice of RAL colours at extra cost
- Electromagnetic or electronic control gear
- Full switching and dimming capability
- Central management system compatible
- Tunnel lighting controls compatible