

P707 Camino

An elegant post top luminaire with photometric performance of the highest efficiency. Designed in four visual profiles to complement or contrast with a range of modern and period architectural features. The Camino has a simple classic style.

FEATURES

- The body, internal mouldings and bowl are manufactured from high impact resistant UV stabilized injection-moulded Polycarbonate.
- Styled top manufactured from aluminium.
- Reflector with tubular lamps.
- Refractor with elliptical lamp options.
- The control gear is contained within the luminaire and is immediately accessible, as is the lamp on removal of the bowl assembly.
- Bowl assembly fitted with a lockable bayonet fixing.
- Finished in black.
- IP65 sealed lamp and gear compartment.

OPTIONS AND EXTRAS

- Available with a 76mm or 60mm spigot.
- Option of prewiring with suitable length of cable.
- Miniature photocell option.
- Electronic control gear on selected lamps.
- PL-T Compact Fluorescent lamp (CFL) option (Refractor only).
- Choice of RAL colours at extra cost – see inside back cover for details.
- Wall bracket option. 5300P707



Recommended Applications: Residential areas, shopping areas, squares, parks, minor roads, footpaths.

Suggested Column: 3 - 5m, for post-top or wall-mounted fixing. P707 specifically designed columns and brackets available.

Wind area: 0.13m²

Spigot PT: 76mm x 76mm
PT: 60mm x 76mm

IP65

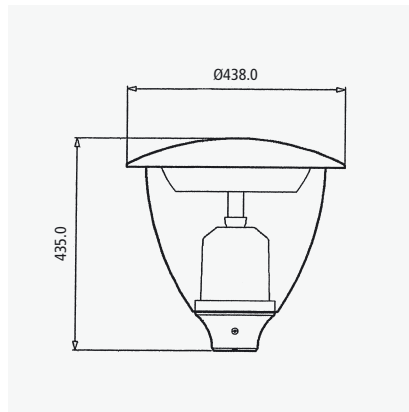

P707 Camino



P707 Camino Reflector



P707 Camino Refractor

Description	Product Number	Weight
Luminaire Reference	P707 CAMINO	4.07
76mm Ø spigot	76	
60mm Ø spigot	60	
Refractor	R	-
Road Lighting Reflector	RF	-
35w CDM control gear (reflector only)	35CDM	1.6 kg
50w SON control gear	50SON	1.6 kg
70w SON control gear	70SON	1.9 kg
70w CDM control gear	70CDM	1.9 kg
42w PL-T electronic gear	42PLT	0.3 kg
Options		
Miniature 1 part photocell	PC	-
Special colour RAL number	RAL	-
Prewired with suitable length of cable	EW	-