

P514 Lantern

Square Victorian period lantern for situations needing a traditional lantern. 3 modern optical system options give versatility of applications.

FEATURES

- Black body
- Clear vandal-resistant one-piece bowl.
- Integral control gear on removable tray for ease of maintenance.
- IP54 sealed lamp and gear compartment.

OPTIONS AND EXTRAS

- Asymmetrical light distribution refractor option (elliptical lamps).
- Two minor road lighting reflector options (tubular lamps).
- Miniature photocell option.
- Choice of RAL colours at extra cost – see inside back cover for details.
- IP66 sealed reflector system option: for 50w and 70w SON-T or 35w CDM-T and 70w CDM-TT.
- 100w SON or CDM-ET lamp option with remote control gear.
- P514 cast wall bracket option.

Recommended Applications: Minor roads, residential areas, shopping areas, squares, parks, footpaths, rail, conservation areas.

Suggested Column: 3.5 - 5m, for post-top or wall bracket fixing.

Wind area: 0.20m²

Spigot: 76mm x 76mm

IP54



P514/R

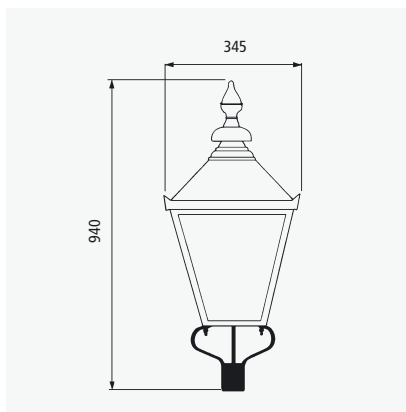

P514



P514 on Promenade column

Description	Product Number	Weight
Luminaire Reference	P514	8.6 kg
26w SOXE control gear	26SOXE	1.7 kg
35w CDM control gear	35CDMT	1.6 kg
35w SOX control gear	35SOX	1.6 kg
50w SON control gear	50SON or SONT	1.6 kg
70w SON control gear	70SON or SONT	1.9 kg
70w CDM control gear	70CDMET or CDMTT	1.9 kg
Options		
Refractor	R	-
Narrow beam reflector	SRRN	-
Medium beam reflector	SRRM	-
Miniature 1 part photocell	MINI	-
Special colour RAL number	RAL	-
Prewired with suitable length of cable	EW	-