

### P511 Lantern

Small traditional Victorian tear-drop style lantern (based on original designs) for city streets, squares, conservation areas, and other situations requiring a Period lantern. Three modern optical system options give efficient performance from a period style lantern.

#### FEATURES

- Black aluminium body in post top or top-entry styles.
- Clear vandal-resistant bowl.
- Integral control gear on removable tray for quick maintenance.
- IP54 sealed lamp and gear compartment.

#### OPTIONS AND EXTRAS

- Top-entry or post top yoke option.
- Asymmetrical light distribution refractor option (elliptical lamps).
- Two minor road lighting reflector options (tubular lamps).
- Miniature photocell option.
- Choice of RAL colours at extra cost – see inside back cover for details.
- IP66 sealed reflector system option: for 50w and 70w SON-T or 35w CDM-T and 70w CDM-TT.
- P511 top entry wall bracket option.



P511/TE/R

Recommended Applications: Residential areas, shopping areas, squares, parks, minor roads, footpaths, rail, conservation areas.

Suggested Column: 3.5 - 5m, for post-top or top-entry/suspended fixing.

Wind area PT: 0.17m<sup>2</sup>  
TE: 0.14m<sup>2</sup>

Spigot PT: 76mm x 76mm  
TE: 1" BSP

IP54



P511/PT/SRR

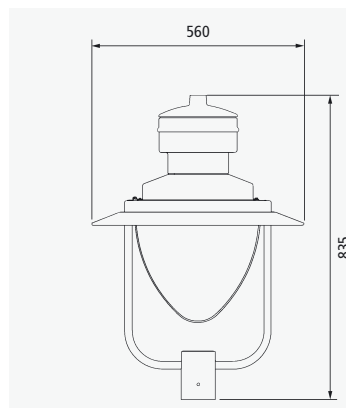

P511 PT

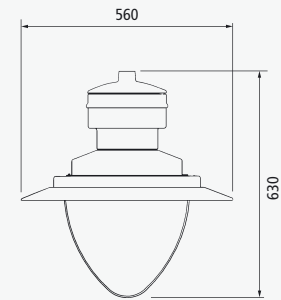

P511 TE

| Description                         | Product Number   | Weight |
|-------------------------------------|------------------|--------|
| Luminaire Reference                 | P511             | 7.8 kg |
| 35w CDM control gear                | 35CDMT           | 1.6 kg |
| 50w SON control gear                | 50SON or SONT    | 1.6 kg |
| 70w SON control gear                | 70SON or SONT    | 1.9 kg |
| 70w CDM control gear                | 70CDMET or CDMTT | 1.9 kg |
| Options                             |                  |        |
| Top entry                           | TE               | -      |
| Post top yoke                       | PT               | -      |
| Refractor                           | R                | -      |
| Narrow beam reflector               | SRRN             | -      |
| Medium beam reflector               | SRRM             | -      |
| Miniature 1 part photocell          | MINI             | -      |
| Special colour RAL number           | RAL              | -      |
| Prewired with suitable length cable | EW               | -      |