

P510 Lantern

Large Victorian tear-drop style lantern (based on original designs) for city streets, squares, conservation areas, and other situations requiring a period lantern. Together with CU Boulevard column an authentic Victorian scheme can be implemented for a modern major road.

FEATURES

- Black aluminium body in post top or top-entry styles.
- Clear vandal-resistant bowl.
- High efficiency variable optic reflector.
- Integral control gear on removable tray for quick maintenance.
- IP54 sealed lamp and gear compartment.

OPTIONS AND EXTRAS

- Top-entry or post top yoke option.
- Choice of RAL colours at extra cost – see inside back cover for details.
- Miniature photocell option.
- P510 top entry wall bracket option.

Recommended Applications: Major roads, residential areas, shopping areas, squares, parks, rail, conservation areas.

Suggested Column: 8 –10m, for post top or top-entry/suspended fixing.

Wind area PT: 0.30m²
TE: 0.24m²

Spigot PT: 76mm x 76mm
TE: 1" BSP

IP54

CE 



P510/TE

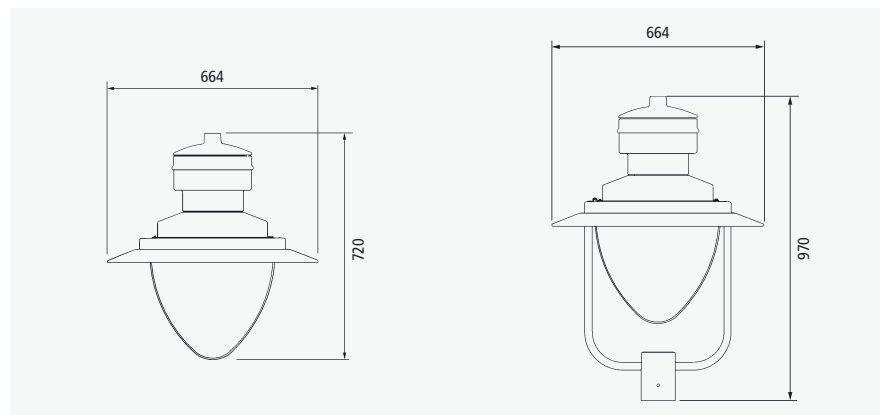

P510 TE

P510 PT



P510/TE Blackfriars Bridge

Description	Product Number	Weight
Luminaire Reference	P510	14.5 kg
100w SON control gear	100SONT	2.1 kg
100w CDM control gear	100CDMTT	2.1 kg
150w SON control gear	150SONT	2.8 kg
150w CDM control gear	150CDMTT	2.8 kg
250w SON control gear	250SONT	3.9 kg
250w MBI control gear	250MBIT	3.9 kg
400w SON control gear	400SONT	5.3kg
400w MBI control gear	400MBIT	5.3 kg
Options		
Top entry	TE	-
Post top yoke	PT	-
Miniature 1 part photocell	MINI	-
Special colour RAL number	RAL	-
Prewired with suitable length of cable	EW	-