

P111 Lantern

A small Regency period lantern for residential roads, and other areas requiring a traditional lantern at minimal cost.

FEATURES

- Black high-pressure die-cast aluminium body.
- One-piece injection-moulded vandal-resistant bowl.
- IP54 sealed lamp and gear compartment.
- Integral control gear for easy maintenance.

OPTIONS AND EXTRAS

- Asymmetrical light distribution refractor option.
- Minor road lighting reflector option (50w and 70w SON/T or 35w and 70w CDM only).
- Miniature photocell option.
- Choice of RAL colours at extra cost – see inside back cover for details.
- 100w and 150w SON and CDM/ET options with remote control gear.
- WB500 wall bracket option.

Recommended Applications: Minor roads, residential areas, shopping areas, squares, parks, footpaths, rail, conservation areas.

Suggested Column: 3.5 - 5m, for post-top or wall bracket fixing.

Wind area: 0.17m²

Spigot: 76mm x 76mm

IP54



P111/Clear/R

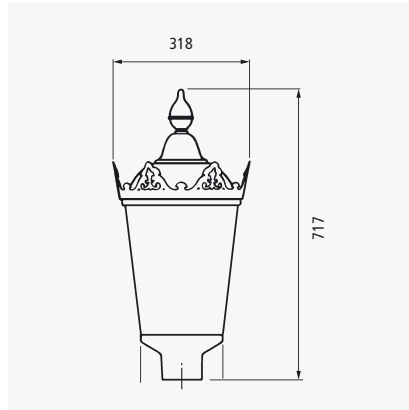

P111



P111 Knutsford

Description	Product Number	Weight
Luminaire Reference	P111	5.0 kg
35w CDM control gear	35CDMT	1.6 kg
26w SOXE control gear	26SOXE	1.7 kg
35w SOX control gear	35SOX	1.6 kg
50w SON control gear	50SON or SONT	1.6 kg
70w SON control gear	70SON or SONT	1.9 kg
70w CDM control gear	70CDMET or CDMTT	1.9 kg
Options		
Clear Bowl	CLEAR	-
Opal Bowl	OPAL	-
Refractor	R	-
Road Lighting Reflector	SRR	-
Miniature 1 part photocell	MINI	-
Special colour RAL number	RAL	-
Prewired with suitable length of cable	EW	-



P111 Burton on the Water



P111 Special on Wall Bracket



P111 Special in Regents Park