

P107 Luminaire

A simple classic post-top lantern with functional design. The canopy is available in two different sizes for different styles and situations.

FEATURES

- Black die-cast aluminium base, and spun aluminium top
- Vandal-resistant injection moulded lens.
- Integral control gear up to 100w SON or CDM, or up to 150w with remote control gear.

OPTIONS AND EXTRAS

- 12" (small) or 24" (large) diameter canopy.
- Clear or opal bowl.
- Refractor system for asymmetrical light distribution.
- Side road reflector (only with clear lens and tubular lamps up to 70w)
- NEMA socket/photocell or miniature photocell option.
- Wall and Corner-wall bracket. WB500 & WB501
- Choice of RAL colours at extra cost – see inside back cover for details.



P107/12/Opal



P107/24/Opal

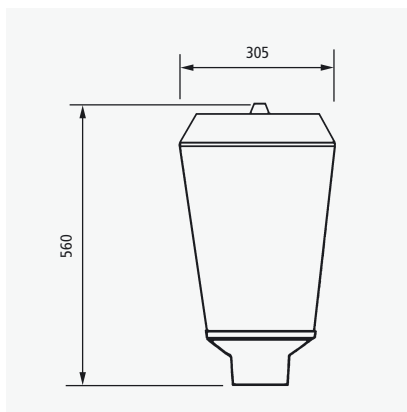

P107/12

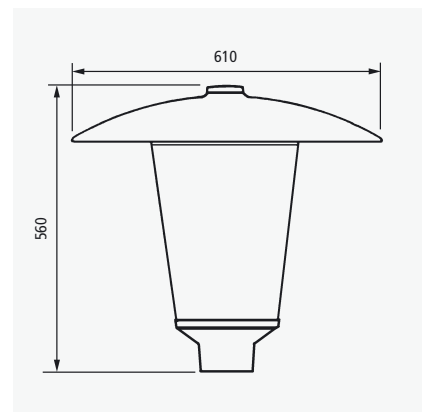

P107/24

Recommended Applications: Minor roads, residential areas, shopping areas, squares, parks, car parks.

Suggested Column: 4 - 5m, for post-top fixing.

Wind area: 0.13m²

Spigot PT: 76mm x 76mm

IP54



Description	Product Number	Weight
Luminaire Reference	P107	5.8 kg
610mm Ø canopy	24	0.3 kg
305mm Ø canopy	12	-
Clear lens	CLEAR	-
Opal lens	OPAL	-
35w CDM control gear	35CDM	1.6 kg
35w SOX control gear	35SOX	1.7 kg
50w SON control gear	50SON	1.6 kg
70w SON control gear	70SON	1.9 kg
70w CDM control gear	70CDM	1.9 kg
100w SON control gear	100SON	2.1 kg
100w CDM control gear	100CDM	2.1 kg
No control gear ES lampholder	ES	-
No control gear GES lampholder	GES	-
Options		
Miniature 1 part photocell	PC	-
NEMA photocell socket	NEMA	-
Duoptic Refractor	R	-
Road lighting reflector	SRR	-
Special colour RAL number	RAL	-
Prewired with suitable length of cable	EW	-