

## COLUMN BOLT FIXING INSTRUCTIONS – J BOLTS

### CASTING THE FOUNDATIONS

It is important that the foundation bolts are cast into the foundations as shown with the thread projecting by the specified dimension.

The template should be positioned on levelling nuts as indicated and clamped in place by the upper nuts.

**REMEMBER THE CABLE DUCT!**

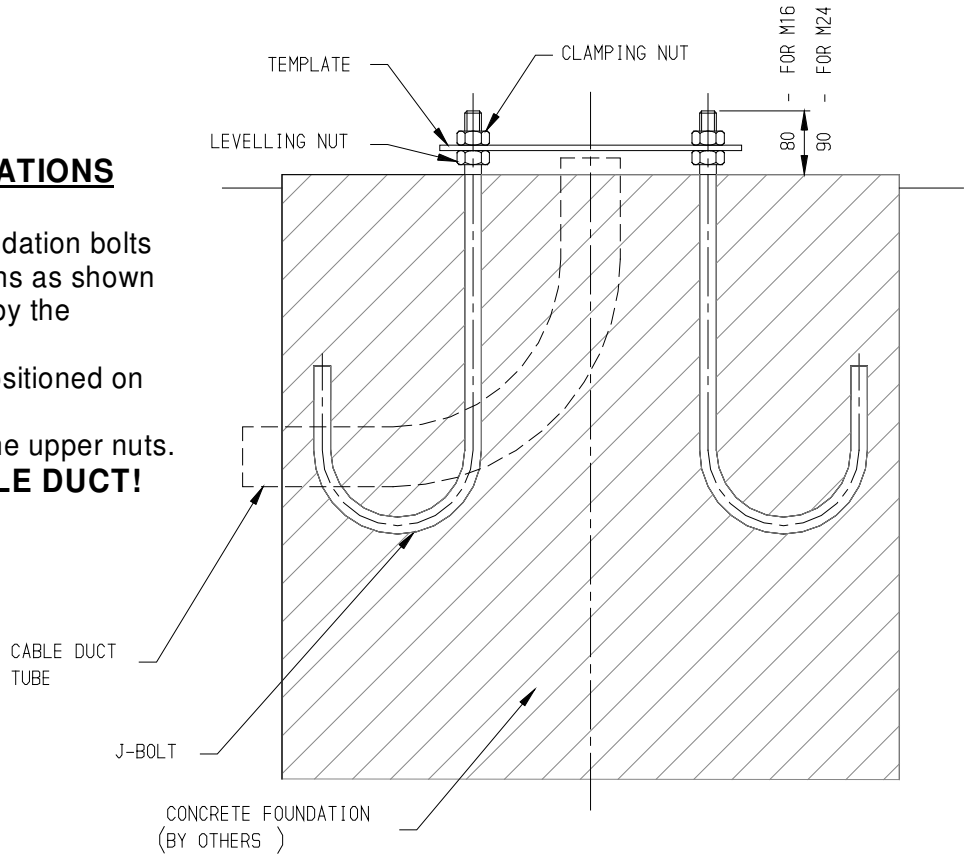

For four hole square flangeplates dry packing is recommended to ensure a uniform bedding. Consideration should be given to the need to provide drainage & ventilation.

**Note:**

Where practical additional corrosion protection to the bolts can be achieved by the use of “Denso” tape (or similar) above the flangeplate.

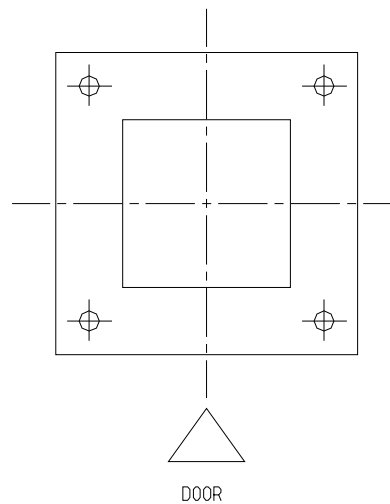

### COLUMN INSTALLATION

**THE TEMPLATE MUST BE REMOVED!**

It is important that all levelling nuts (where used) bear uniformly on the underside of the flangeplate and that all clamping nuts are tightened in accordance with the installation and erection instructions.

Where levelling nuts are not used, dry packing should be well rammed around temporary shims, then shims removed and dry packing completed.

